

► **Code Number**

3450049

► **Description**

Exposed, Sensor Activated Sloan® Model Water Closet Flushometer, for floor mounted or wall hung top spud bowls.

► **Flush Cycle**

Model 111-1.28 ES-S High Efficiency (1.28 gpf/4.8 Lpf)

► **Specifications**

Quiet, Exposed, Diaphragm Type, Chrome Plated Closet Flushometer with the following features:

- High Chloramine Resistant PERMEX® Synthetic Rubber Diaphragm with Dual Filtered Bypass
- Flush Accuracy Controlled by CID Technology
- Diaphragm, Stop Seat and Vacuum Breaker to be molded from PERMEX® rubber compound for Chloramine resistance
- User friendly three (3) second Flush Delay
- Sweat Solder Adapter w/Cover Tube and Cast Wall Flange w/Set Screw
- Courtesy Flush® Override Button
- OPTIMA® EL-1500-L Self-Adaptive Infrared Sensor with Indicator Light
- Die Cast Sensor Plate with no visible Fasteners (for 2-gang Electrical Box)
- High Back Pressure Vacuum Breaker Flush Connection with One-Piece Bottom Hex Coupling Nut, Spud Coupling and Flange for 1½" Top Spud
- Non-Hold-Open Integral Solenoid Operator, Fixed Metering Bypass and No External Volume Adjustment to Ensure Water Conservation
- Die Cast Solenoid Wall Cover Plate with no visible Fasteners (for 2-gang Electrical Box)
- 1. I.P.S. Screwdriver Bak-Chek® Angle Stop with Free Spinning Vandal Resistant Stop Cap

Valve Body, Cover, Tailpiece and Control Stop shall be in conformance with ASTM Alloy Classification for Semi-Red Brass. Valve shall be in compliance with the applicable sections of ASSE 1037 and ANSI/ASME A112.19.2. Installation conforms to ADA requirements.

► **Accessories**

- Transformer (120 VAC/24 VAC, 50 VA)
- Transformer (240 VAC/24 VAC, 50 VA)
- Flushometer Electrical Box Positioning and Support Kit

See Accessories Section and OPTIMA® Accessories Section of the Sloan catalog for details on these and other OPTIMA® Flushometer variations.

► **ELECTRICAL SPECIFICATIONS**

Control Circuit

- Solid State
- 8 Second Arming Delay
- 3 Second Flush Delay
- 24 VAC Input
- 24 VAC Output
- 24-Hour Sentinel Flush



► **Automatic Operation**

Sloan OPTIMA® equipped Flushometers provide the ultimate in sanitary protection and automatic operation. There are no handles to trip or buttons to push. The Flushometer operates by means of an infrared sensor that adapts to its surrounding. Once the user enters the sensor's effective range and then steps away, the Flushometer Solenoid initiates the flushing cycle to flush the fixture.

► **Hygienic**

User makes no physical contact with the Flushometer surface except to initiate the Override Button when required. Helps control the spread of infectious diseases. 24-Hour Sentinel Flush keeps fixture fresh during periods of nonuse.

► **Practical**

Solid state electronic circuitry assures years of dependable, troublefree operation. The operational components of the Flushometer are identical to a handle activated Royal® Flushometer, proven by over 100 years of experience.

► **Economical**

Automatic operation provides water usage savings over other flushing devices. Reduces maintenance and operation costs.

► **Fixtures**

Consult factory to match Sloan fixture options.

► **Compliance**



This space for Architect/Engineer Approval

Sensor Range

- Nominal 22" - 42" (559 mm - 1067 mm) Self-adaptive Window: ± 10" (254 mm)

Solenoid Operator

- 24 VAC, 50/60 Hz

Transformers

- Sloan Part #EL-154 120 VAC, 50/60 Hz Primary 24 VAC, 50/60 Hz Secondary Class II, UL Listed, 50 VA.
- Sloan Part #EL-342 240 VAC, 50/60 Hz Primary 24 VAC, 50/60 Hz Secondary Class II, UL Listed, 50 VA.

► ROUGH-IN

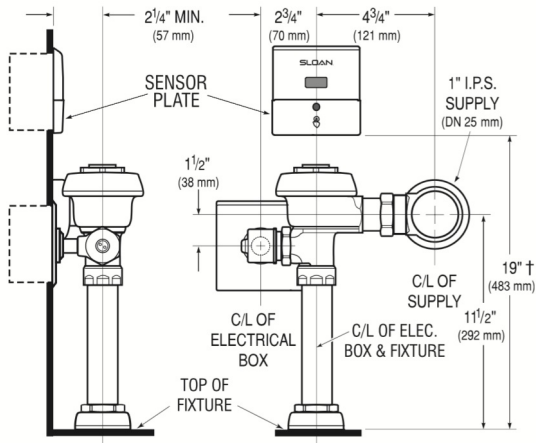

† Position of Sensor Box can be raised or lowered 1" (25 mm) if in conflict with Handicap Grab Bars.

† Position of Sensor Box can be raised or lowered 1" (25 mm) if in conflict with Handicap Grab Bars.

► WIRING DIAGRAM

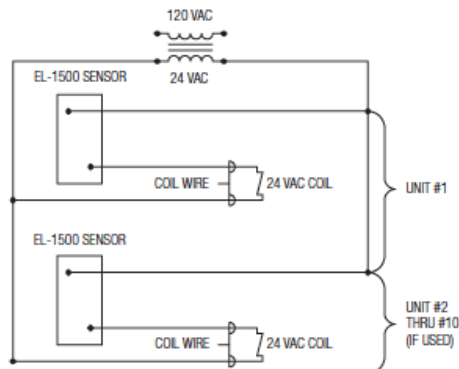

One Transformer serves up to ten (10) OPTIMA Closet/Urinal Flushometers. Specify number of transformers required accordingly.

► OPERATION

1. A continuous, invisible light beam is emitted from the OPTIMA® Sensor.

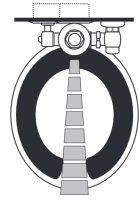

2. As the user enters the beam's effective range (22" to 42") the beam is reflected into the OPTIMA® Scanner Window and transformed into a low voltage electrical circuit. Once activated, the Output Circuit continues in a "hold" mode for as long as the user remains within the effective range of the Sensor.

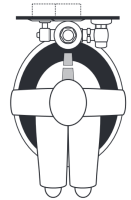

3. When the user steps away from the OPTIMA® Sensor, the circuit waits 3 seconds (to prevent false flushing) then initiates an electrical "one-time" signal that operates the Solenoid. This initiates the flushing cycle to flush the fixture. The Circuit then automatically resets and is ready for the next user.

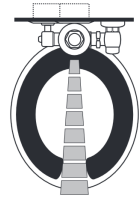

► ELECTRICAL BOX INSTALLATION

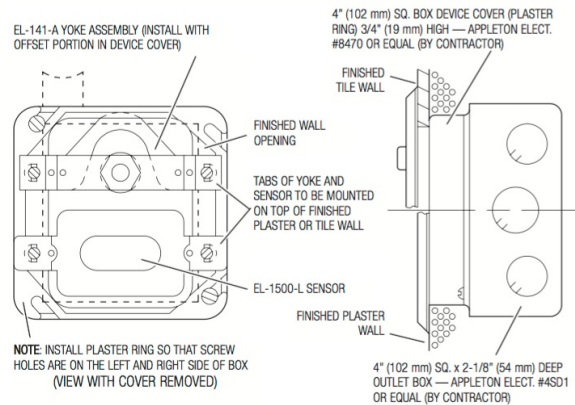

Failure to properly position the electrical boxes to the plumbing rough-in will result in improper installation and impair product performance. All tradesmen (plumbers, electricians, tile setters, etc.) involved with the installation of this product must coordinate their work to assure proper product installation. Installation Template furnished with Flushometer.

To ensure a perfect rough-in, Sloan recommends the use of the EL-485-A Flushometer Electrical Box Positioning and Support Kit. Specify and order the EL 485-A Kit separately. Consult factory for installation details.